

# PREMIER

ATTACHMENTS™

PRODUCT CATALOG



POWER THROUGH  
ANY PROJECT

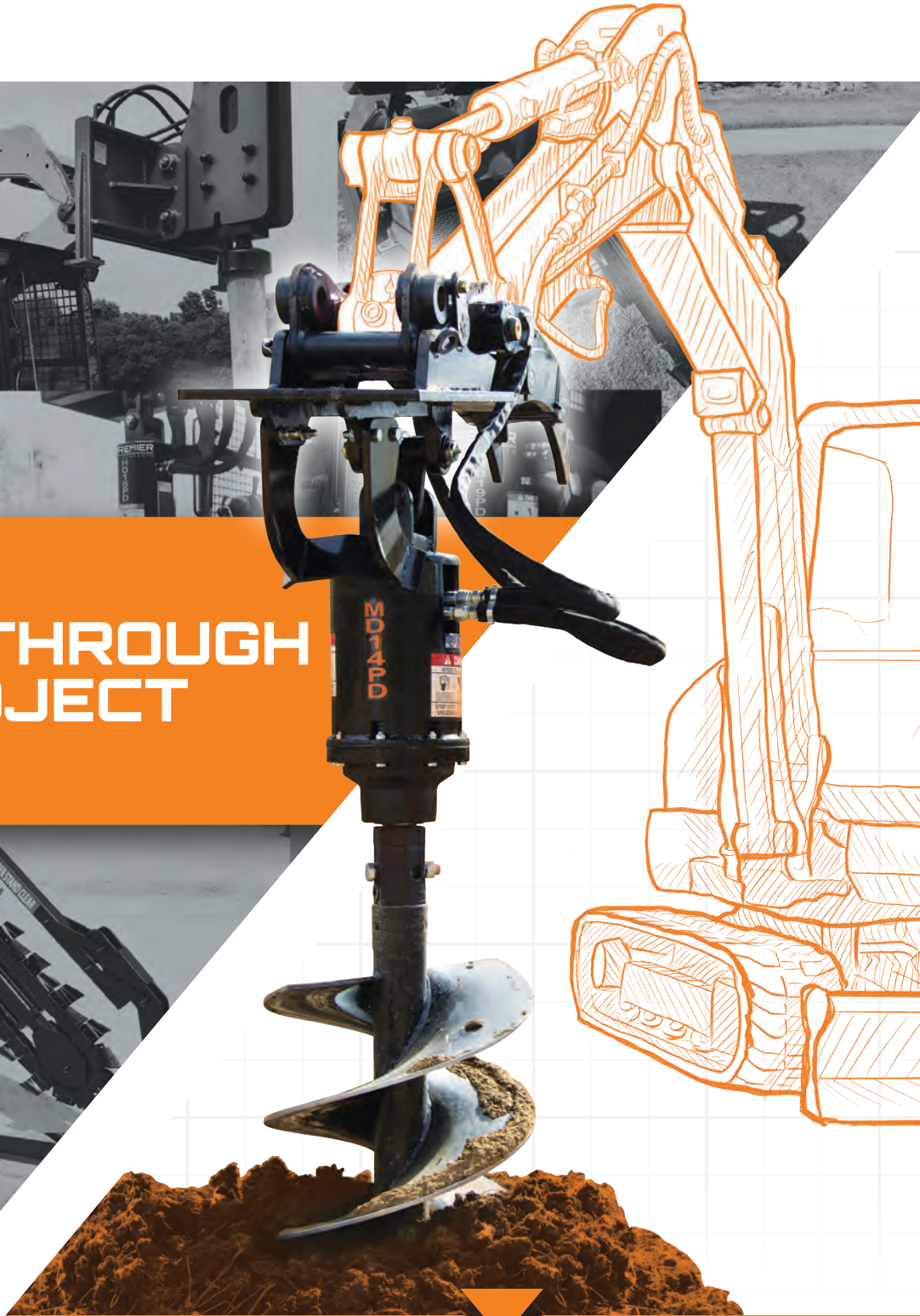

PREMIERATTACH.COM



# THANK YOU FOR STANDING WITH US.

Because of you, our midwest company has run strong through this last year. It's been hard. It has not been without sacrifice. But, because of you, we've never skipped a beat. Sure some things had to adapt. But, a few things will never change. Like our dedication to quality. Our dedication to delivering value. And our dedication to you.

**Thank you.**





THE FIBER OPTIC CENTER





# PREMIER<sup>™</sup>

## ATTACHMENTS

### TABLE OF CONTENTS

- 4 AUGER DRIVE OVERVIEW
- 5 AUGER DRIVES
- 10 MOUNTS
- 11 AUGERS
- 15 AUGER TEETH
- 16 ACCESSORIES
- 17 POST DRIVERS
- 19 TRENCHERS
- 21 AMMBUSHER
- 23 PALLET FORKS
- 25 UTILITY EQUIPMENT

### TABLE KEY

Throughout this catalog, you will see icons similar to the example shown to the right. The colors on this icon represents the types of machines that are compatible with the relative Premier products. If you do not see your machine listed, give us a call.





# PREMIER EARTH AUGERS

POWER FOR VIRTUALLY ANY DIGGING APPLICATION

Premier Attachments, with our modern state-of-the-art manufacturing facility located in Fort Wayne IN, has built the most reliable earth auger attachments for over two decades. With a complete and comprehensive line of earth auger drive units, mounts, augers, adapters, extensions, teeth, and accessories, rest assured that Premier is the single source for all your earth auger needs.



## PREMIER POWER

Premier hydraulic earth auger drive units utilize the power of the host machine to turn it into a high-performance drilling machine. Without leaving the vehicle seat, an equipment operator can dig countless holes in the harshest digging conditions. Fence posts, foundation footings, tree planting, utility poles, and many others that require vertical or angled holes are at their control.

## PREMIER VERSATILITY

Premier earth auger attachments adapt to skid steer loaders, mini skid steer loaders, wheel loaders, tractors, backhoes, excavators, forklifts, cranes, digger derricks, mini digger derricks, and other hydraulic machinery. The Duo-Tach™ Mounting System (Patent No. 11,280,057) allows attachments to fit both Mini Skid Steer Loaders and Full-Size Skid Steer Loaders.



## PREMIER SERVICE

With the best lead times in the industry, we provide the best solution for your digging needs with the best delivery date possible.

## PREMIER WARRANTY

Premier Attachments takes great pride in the quality and reliability of our products. We offer the best warranties in the industry.

SKID STEER LOADERS

MINI SKID STEER LOADERS

TRACTOR LOADERS

BACKHOES

EXCAVATORS

MINI EXCAVATORS

PREMIERATTACH.COM

1.866.458.0008



# AUGER DRIVES

## MINI-SKID LOADER AUGER DRIVES

MS11PD		GPM   RPM	PSI   TORQUE	OUTPUTS	WARRANTY
MAX AUGER DIAM	24"	7   45	2,500   1,274	2" HEX -OR- 2-1/2" RND	3 YEARS
MIN HYD GPM	6 GPM	9   58	3,000   1,529		
MAX HYD GPM	12 GPM	11   71	3,500   1,783		
MAX HYD PSI	3500 PSI				
MS14PD		GPM   RPM	PSI   TORQUE	OUTPUTS	WARRANTY
MAX AUGER DIAM	30"	12   50	2,500   1,825	2" HEX -OR- 2-1/2" RND	3 YEARS
MIN HYD GPM	10 GPM	15   61	3,000   2,190		
MAX HYD GPM	20 GPM	17   71	3,500   2,555		
MAX HYD PSI	3500 PSI				
MS18PD		GPM   RPM	PSI   TORQUE	OUTPUTS	WARRANTY
MAX AUGER DIAM	36"	15   50	2,500   2,290	2" HEX -OR- 2-1/2" RND	3 YEARS
MIN HYD GPM	15 GPM	18   60	3,000   2,748		
MAX HYD GPM	25 GPM	20   67	3,500   3,206		
MAX HYD PSI	3500 PSI				

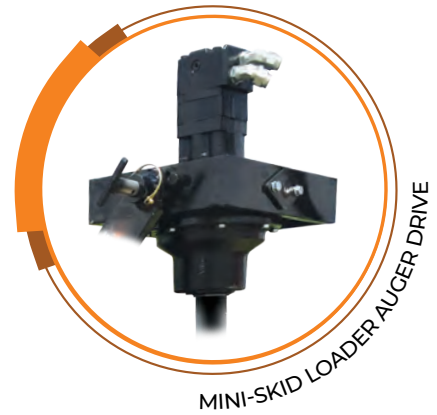

MINI-SKID LOADER AUGER DRIVE

### IDEAL RPM RANGE

MODEL #	GPM						
	6	9	11	12	15	17	20
MS11PD	45	58	71				
MS14PD				50	61	71	
MS18PD					50	60	67

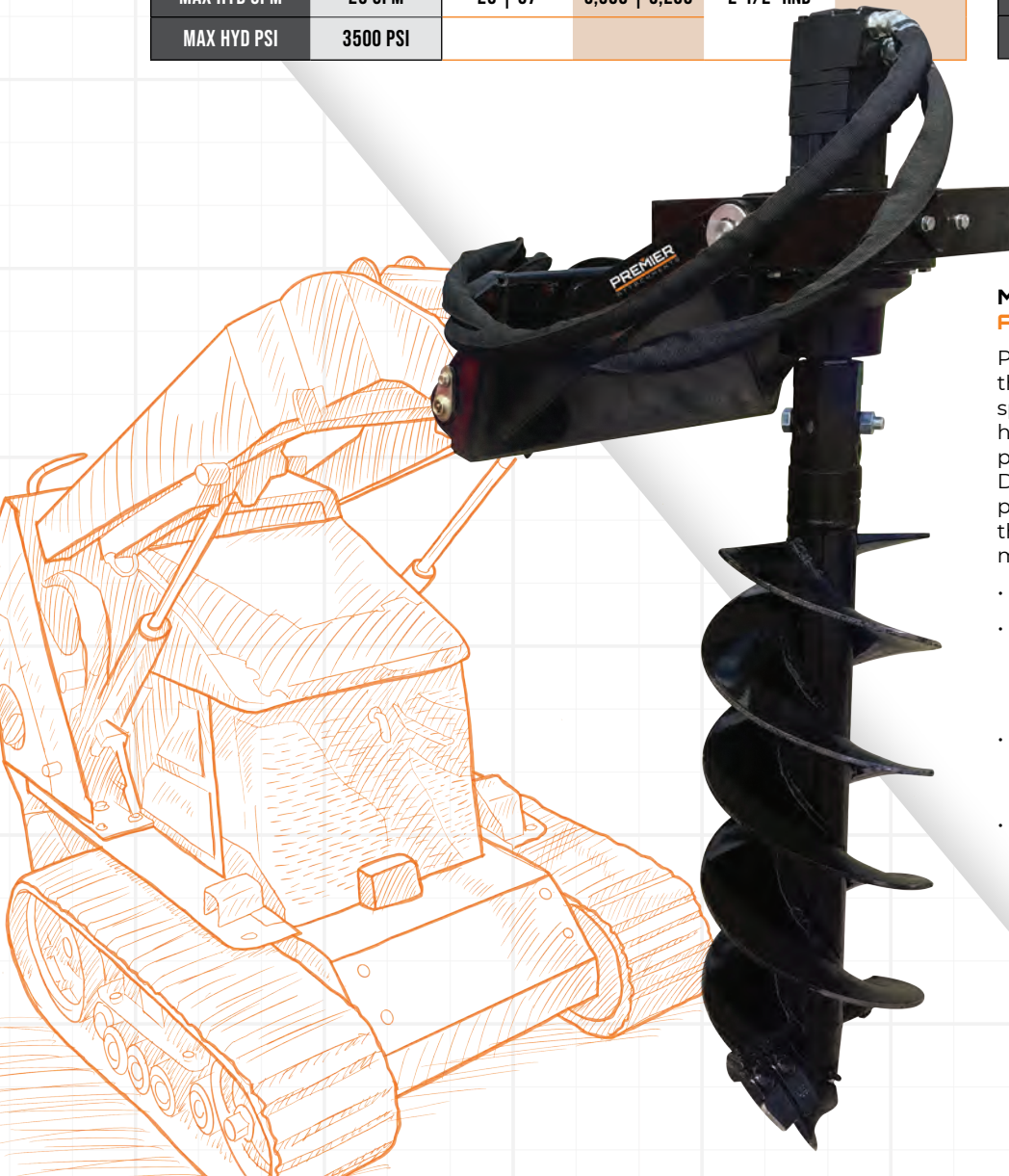

### MINI-SKID LOADER AUGER DRIVES (MS-SERIES)

Premier Attachments produces three Mini Skid Steer Auger Drives specifically designed for the hydraulics GPM and PSI of this popular machine. These Medium-Duty Auger Drives are cost-effective, powerful, and designed to maximize the hydraulics of the various machinery available.

- 3 Year Warranty
- We offer mounting brackets that include the Universal Mini Skid Steer mount as well as the Bobcat MT mount
- A full range swivel that allows the auger to hang plumb to the ground at any angle
- Output shafts available in 2" hexagon and 2-9/16" round



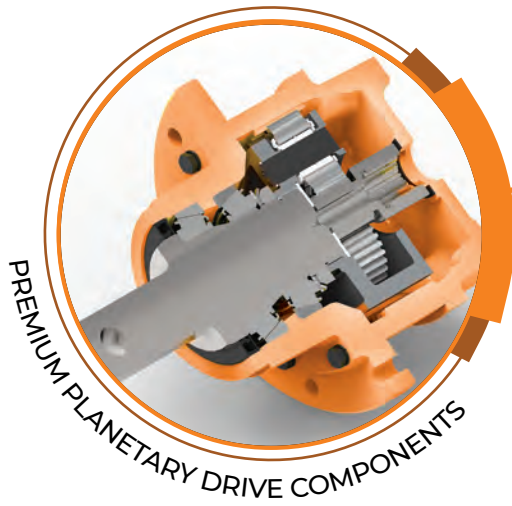

### STANDARD DUTY AUGER DRIVES

MD06PD		GPM   RPM	PSI   TORQUE	OUTPUTS	WARRANTY
MAX AUGER DIAM	15"	5   52	2,500   734	2" HEX	3 YEARS
MIN HYD GPM	5 GPM	7   73	3,000   881		
MAX HYD GPM	10 GPM	9   93	3,500   1,028		
MAX HYD PSI	3500 PSI	10   104			
MD09PD		GPM   RPM	PSI   TORQUE	OUTPUTS	WARRANTY
MAX AUGER DIAM	18"	7   48	2,500   1,123	2" HEX	3 YEARS
MIN HYD GPM	7 GPM	9   61	3,000   1,347		
MAX HYD GPM	14 GPM	11   75	3,500   1,571		
MAX HYD PSI	3500 PSI	13   88			
MD12PD		GPM   RPM	PSI   TORQUE	OUTPUTS	WARRANTY
MAX AUGER DIAM	24"	9   49	2,500   1,409	2" HEX	3 YEARS
MIN HYD GPM	8 GPM	11   59	3,000   1,691		
MAX HYD GPM	17 GPM	13   71	3,500   1,972		
MAX HYD PSI	3500 PSI	15   81			
MD14PD		GPM   RPM	PSI   TORQUE	OUTPUTS	WARRANTY
MAX AUGER DIAM	30"	12   50	2,500   1,825	2" HEX -OR- 2-9/16" RND	3 YEARS
MIN HYD GPM	10 GPM	15   61	3,000   2,190		
MAX HYD GPM	20 GPM	17   71	3,500   2,555		
MAX HYD PSI	3500 PSI	20   83			
MD18PD		GPM   RPM	PSI   TORQUE	OUTPUTS	WARRANTY
MAX AUGER DIAM	36"	15   50	2,500   2,290	2" HEX -OR- 2-9/16" RND	3 YEARS
MIN HYD GPM	15 GPM	18   60	3,000   2,748		
MAX HYD GPM	30 GPM	20   67	3,500   3,206		
MAX HYD PSI	3500 PSI	25   83			

### SKID STEER, TRACTOR, & MINI-EXCAVATOR EARTH AUGER DRIVES (MD-SERIES)

Premier Attachments offers five models in the Standard Duty MD-Series Auger Drives. The Standard Duty auger drive is designed for light to moderate drilling conditions at competitive prices.

- No drain line is required
- 3 Year Warranty
- All Auger Drives are designed and engineered for the higher hydraulic pressures of today's equipment
- Universal Skid Steer mount is an industry standard for all makes and models, however we do offer late model obsolete mounts for those older machines
- Output shafts available in 2" hexagon and 2-9/16" round

### IDEAL RPM RANGE

MODEL #	GPM											
	6	7	9	10	11	12	13	15	17	18	20	25
MD06PD	62	73	93	104								
MD09PD		48	61		75	88						
MD12PD			49		59	71	81					
MD14PD						50	61	71		83		
MD18PD							50	60	67	83		





## HEAVY DUTY AUGER DRIVES

H010PD		GPM   RPM	PSI   TORQUE	OUTPUTS	WARRANTY
MAX AUGER DIAM	24"	8   48	2,500   1,274	2" HEX -OR- 2-9/16" RND	5 YEARS
MIN HYD GPM	6 GPM	10   60	3,000   1,529		
MAX HYD GPM	15 GPM	12   72	3,500   1,783		
MAX HYD PSI	3,500 PSI	15   90			
H015PD		GPM   RPM	PSI   TORQUE	OUTPUTS	WARRANTY
MAX AUGER DIAM	30"	12   47	2,500   1,975	2" HEX -OR- 2-9/16" RND	5 YEARS
MIN HYD GPM	10 GPM	15   58	3,000   2,372		
MAX HYD GPM	25 GPM	17   66	3,500   2,768		
MAX HYD PSI	3,500 PSI	20   78			
H019PD		GPM   RPM	PSI   TORQUE	OUTPUTS	WARRANTY
MAX AUGER DIAM	36"	15   46	2,500   2,481	2" HEX -OR- 2-9/16" RND	5 YEARS
MIN HYD GPM	15 GPM	18   56	3,000   2,977		
MAX HYD GPM	30 GPM	20   62	3,500   3,474		
MAX HYD PSI	3,500 PSI	25   77			
H024PD		GPM   RPM	PSI   TORQUE	OUTPUTS	WARRANTY
MAX AUGER DIAM	36"	20   48	2,500   3,184	2" HEX -OR- 2-9/16" RND	5 YEARS
MIN HYD GPM	20 GPM	24   58	3,000   3,821		
MAX HYD GPM	35 GPM	26   63	3,250   4,140		
MAX HYD PSI	3,250 PSI	30   72			

## IDEAL RPM RANGE

MODEL #	GPM									
	8	10	12	15	17	18	20	24	25	30
H010PD	48	60	72	90						
H015PD			47	58	66		78			
H019PD				46		56	62		77	
H024PD							48	58	63	72

### SKID STEER & MINI-EXCAVATOR EARTH AUGER DRIVES (H0-SERIES)

Premier Attachments offers four models in the Heavy Duty H0-Series Auger Drives. The Heavy-Duty auger drives are built with industrial grade components for the toughest of drilling conditions.

- No drain line is required
- 5 Year Warranty
- All Auger Drives are designed and engineered for the higher hydraulic pressures of today's equipment
- Universal Skid Steer mount is an industry standard for all makes and models, however we do offer late model obsolete mounts for those older machines
- Output shafts available in 2" hexagon and 2-9/16" round
- Premier's proprietary Labyrinth Seal allows for multiple sealing surfaces within the seal to defend against dirt coming in and oil leaking out. The five different seals outperform the basic double seal used by other manufacturers.







## HIGH FLOW/HIGH TORQUE AUGER DRIVES

H040PD		GPM   RPM	PSI   TORQUE	OUTPUTS	WARRANTY
MAX AUGER DIAM	48"	20   53	2,500   2,861	2" HEX -OR- 2-1/2" HEX	5 YEARS
MIN HYD GPM	20 GPM	25   67	3,000   3,433		
MAX HYD GPM	45 GPM	30   80	3,500   4,005		
MAX HYD PSI	4,500 PSI	35   94	4,000   4,578		
H045PD		GPM   RPM	PSI   TORQUE	OUTPUTS	WARRANTY
MAX AUGER DIAM	48"	25   53	2,500   3,624	2" HEX -OR- 2-1/2" HEX	5 YEARS
MIN HYD GPM	25 GPM	30   63	3,000   4,349		
MAX HYD GPM	45 GPM	35   74	3,500   5,074		
MAX HYD PSI	4,500 PSI	40   85	4,000   5,798		
H055PD		GPM   RPM	PSI   TORQUE	OUTPUTS	WARRANTY
MAX AUGER DIAM	48"	35   58	2,500   4,578	2" HEX  2-1/2" HEX	5 YEARS
MIN HYD GPM	30 GPM	40   67	3,000   5,493		
MAX HYD GPM	60 GPM	45   75	3,500   6,409		
MAX HYD PSI	4,500 PSI	50   84	4,000   7,325		
H065PD		GPM   RPM	PSI   TORQUE	OUTPUTS	WARRANTY
MAX AUGER DIAM	48"	40   54	2,500   5,722	2" HEX -OR- 2-1/2" HEX	3 YEARS
MIN HYD GPM	30 GPM	45   60	3,000   6,867		
MAX HYD GPM	60 GPM	50   67	3,500   8,011		
MAX HYD PSI	4,500 PSI	55   74	4,000   9,156		
H075PD		GPM   RPM	PSI   TORQUE	OUTPUTS	WARRANTY
MAX AUGER DIAM	48"	40   43	3,000   8,527	2-1/2" HEX	3 YEARS
MIN HYD GPM	30 GPM	45   49	3,500   9,948		
MAX HYD GPM	60 GPM	50   54	4,000   11,369		
MAX HYD PSI	4,500 PSI	60   65	4,500   12,790		
H085PD		GPM   RPM	PSI   TORQUE	OUTPUTS	WARRANTY
MAX AUGER DIAM	48"	40   54	2,500   8,957	2-1/2" HEX	3 YEARS
MIN HYD GPM	30 GPM	45   39	3,000   10,748		
MAX HYD GPM	60 GPM	50   43	3,500   12,539		
MAX HYD PSI	3,500 PSI	55   51			
H095PD		GPM   RPM	PSI   TORQUE	OUTPUTS	WARRANTY
MAX AUGER DIAM	48"	45   30	2,500   11,213	2-1/2" HEX	2 YEARS
MIN HYD GPM	30 GPM	50   34	3,000   13,455		
MAX HYD GPM	60 GPM	55   37	3,500   15,698		
MAX HYD PSI	4,500 PSI	60   41	4,000   17,941		
H0120PD		GPM   RPM	PSI   TORQUE	OUTPUTS	WARRANTY
MAX AUGER DIAM	48"	30   15	2,500   15,790	3" HEX	2 YEARS
MIN HYD GPM	30 GPM	45   22	3,000   18,949		
MAX HYD GPM	60 GPM	60   29	3,500   22,107	4" SQUARE	
MAX HYD PSI	3,500 PSI				
H0130PD		GPM   RPM	PSI   TORQUE	OUTPUTS	WARRANTY
MAX AUGER DIAM	48"	30   9	2,500   25,212	4" SQUARE	2 YEARS
MIN HYD GPM	30 GPM	45   14	3,000   30,254		
MAX HYD GPM	60 GPM	60   18	3,500   35,297		
MAX HYD PSI	3,500 PSI				



### HIGH FLOW SKID STEER & EXCAVATOR EARTH AUGER DRIVES (H0-SERIES)

Premier Attachments offers nine models of the Heavy-Duty High flow Auger Drives. Our Heavy-Duty High Flow auger drives are specifically designed to maximize the high flow capability of torque and speed.

- No drain line is required
- 2, 3, and 5 Year Warranty
- All Auger Drives are designed and engineered for the higher hydraulic pressures of today's equipment
- Universal Skid Steer mount is an industry standard for all makes and models, however we do offer late model obsolete mounts for those older machines
- Output shafts available in 2" hexagon, 2-1/2" hexagon, 3" Hexagon, and 4" Square

### IDEAL RPM RANGE

MODEL #	GPM								
	20	25	30	35	40	45	50	55	60
H040PD	53	67	80	94					
H045PD		53	63	74	85				
H055PD				58	67	75	84		
H065PD					54	60	67	74	
H075PD					43	49	54	65	
H085PD					54	39	43	51	
H095PD						30	34	37	41
H0120PD			15			22			29
H0130PD				9		14			18

TORQ-HUB INFORMATION ON PAGE 16

SKID STEER LOADERS

MINI SKID STEER LOADERS

TRACTOR LOADERS

BACKHOES

EXCAVATORS

MINI EXCAVATORS



# AUGER DRIVES

## 2-SPEED AUGER DRIVES STANDARD FLOW

H203 2-SPEED		HIGH SPEED		LOW SPEED		OUTPUTS	WARRANTY
		GPM   RPM	PSI   TORQUE	GPM   RPM	PSI   TORQUE		
MAX AUGER DIAM	36"	13   82	2,500   1,219	13   40	2,500   2,448	2" HEX -OR- 2-1/2" HEX	2 YEARS
MIN HYD GPM	13 GPM	15   94	3,000   1,462	15   47	3,000   2,934		
MAX HYD GPM	17 GPM	17   107	3,500   1,706	17   53	3,500   3,426		
MAX HYD PSI	3,500 PSI						
H204 2-SPEED		HIGH SPEED		LOW SPEED		OUTPUTS	WARRANTY
		GPM   RPM	PSI   TORQUE	GPM   RPM	PSI   TORQUE		
MAX AUGER DIAM	48"	15   74	2,500   1,542	15   37	2,500   3,085	2" HEX -OR- 2-1/2" HEX	2 YEARS
MIN HYD GPM	15 GPM	17   84	3,000   1,851	17   42	3,000   3,702		
MAX HYD GPM	19 GPM	19   94	3,500   2,159	19   47	3,500   4,319		
MAX HYD PSI	3,500 PSI						
H205 2-SPEED		HIGH SPEED		LOW SPEED		OUTPUTS	WARRANTY
		GPM   RPM	PSI   TORQUE	GPM   RPM	PSI   TORQUE		
MAX AUGER DIAM	48"	17   66	2,500   1,985	17   33	2,500   3,965	2" HEX -OR- 2-1/2" HEX	2 YEARS
MIN HYD GPM	17 GPM	19   73	3,000   2,382	19   37	3,000   4,759		
MAX HYD GPM	21 GPM	21   81	3,500   2,779	21   40	3,500   5,552		
MAX HYD PSI	3,500 PSI						
H208 2-SPEED		HIGH SPEED		LOW SPEED		OUTPUTS	WARRANTY
		GPM   RPM	PSI   TORQUE	GPM   RPM	PSI   TORQUE		
MAX AUGER DIAM	48"	19   49	2,500   2,961	19   24	2,500   5,921	2" HEX -OR- 2-1/2" HEX	2 YEARS
MIN HYD GPM	19 GPM	22   57	3,000   3,553	22   28	3,000   7,106		
MAX HYD GPM	25 GPM	25   65	3,500   4,145	25   32	3,500   8,290		
MAX HYD PSI	3,500 PSI						

## 2-SPEED AUGER DRIVES HIGH FLOW/HIGH TORQUE

H215 2-SPEED		HIGH SPEED		LOW SPEED		OUTPUTS	WARRANTY
		GPM   RPM	PSI   TORQUE	GPM   RPM	PSI   TORQUE		
MAX AUGER DIAM	48"	30   26	2,500   7,895	30   12	2,500   11,843	2-1/2" HEX	2 YEARS
MIN HYD GPM	30 GPM	40   34	2,750   8,684	40   26	2,750   13,027		
MAX HYD GPM	50 GPM	50   43	3,500   9,471	50   33	3,500   14,211		
MAX HYD PSI	3,000 PSI						
H230 2-SPEED		HIGH SPEED		LOW SPEED		OUTPUTS	WARRANTY
		GPM   RPM	PSI   TORQUE	GPM   RPM	PSI   TORQUE		
MAX AUGER DIAM	48"	30   12	2,500   18,577	30   8	2,500   27,866	3" HEX	2 YEARS
MIN HYD GPM	30 GPM	40   17	2,750   20,435	40   11	2,750   30,652		
MAX HYD GPM	50 GPM	50   21	3,500   22,292	50   14	3,500   33,439		
MAX HYD PSI	3,000 PSI						

TORQ-HUB INFORMATION ON PAGE 16

## SKID STEER LOADER MOUNTS

- Universal Skid Steer Mount
- Down Pressure Mount (*Additional weights sold separately*)
- High Reach Mount Extensions

## BACKHOE, MINI-EXCAVATOR, & EXCAVATOR MOUNTS

- Pin-on Mounts
- Pin Grabber Style Mounts
- Dedicated Quick Attach Systems

## AG-STYLE EQUIPMENT MOUNTS

- Off-set universal Skid Steer Mount
- Euro/Universal Loader Mount
- John Deere 200 – 500 Tractor Loader Mounts
- John Deere 600 & 700 Mounts
- Tractor Loader Mounts



## SKID STEER LOADER MOUNTS

MODEL #	DESCRIPTION
SM001	UNIVERSAL SKID STEER MOUNT SAE J2513
SMHD001	UNIVERSAL SKID STEER MOUNT FOR HIGH TORQUE AUGER DRIVES
SM026	DOWN PRESSURE MOUNT BASE
SM028	DEDICATED HIGH REACH MOUNT

## BACKHOE MOUNTS

MODEL #	DESCRIPTION
BH001	CASE 580/590 B THROUGH M SERIES PIN-ON
BH002	JOHN DEERE 310/410/510 PIN-ON
BH006	JOHN DEERE 310SE-K/410SE-K SERIES PIN-ON
BH003	CATERPILLAR 416/426/428/436 PIN-ON
BH004	NEW HOLLAND 400/500/600/700 SERIES PIN-ON
BH005	JCB 1400/1700 PIN-ON
BH110	CASE 580-N SERIES PIN-ON
BH116	NEW HOLLAND 90-B/95-B/110-B

## MISC WEAR PARTS

MODEL #	DESCRIPTION
91001	KNUCKLE PIN
91002	SWIVEL
91003	CRADLE

OTHER MOUNTS AVAILABLE UPON REQUEST

## HEAVY DUTY WELD-ON MOUNT BLANK

MODEL #	DESCRIPTION
95009	WELD-ON ADAPTER, 5/16" STEEL PLATE
95021	WELD-ON ADAPTER, 3/8" STEEL PLATE
50124	MINI SKID MOUNT PLATE
95029	BOBCAT MT MOUNT PLATE

## BACKHOE, MINI-EXCAVATOR, & EXCAVATOR MOUNTS

MODEL #	DESCRIPTION
VARIES	PIN SIZES: ( 1-1/4" TO 1-3/4"), (55MM TO 85MM+)

## AG-STYLE EQUIPMENT MOUNTS

MODEL #	DESCRIPTION
SM020	OFF-SET UNIVERSAL SKID STEER MOUNT
SM021	EURO/UNIVERSAL LOADER MOUNT
SM019	JOHN DEERE 200-500 TRACTOR LOADER MOUNT
SM027	JOHN DEERE 600-700
TM001	TRACTOR LOADER MOUNTS

## EXCAVATOR & BACKHOE DEDICATED QUICK ATTACH MOUNTS

MODEL #	DESCRIPTION
BH099	BOBCAT QUICK ATTACH MOUNT
BH011	KUBOTA KX71-3 THROUGH KX121-3/U35/KX40
BH010	KUBOTA KX161-3/U45 MOUNT
BH065	KUBOTA KX080-3 MOUNT
BH141	KUBOTA KX057 COUPLER MOUNT
BH078	TAG/C&P WAIN ROY STYLE #027 MOUNT
BH097	TAG/C&P WAIN ROY STYLE #030 MOUNT
BH064	JOHN DEERE 35-G COUPLER MOUNT
BH091	JOHN DEERE 50-G COUPLER MOUNT
BH150	JOHN DEERE 17-G COUPLER MOUNT

## ACCESSORIES

MODEL #	DESCRIPTION
50202	WEIGHTS FOR DOWN PRESSURE MOUNT 100 LBS. EACH





CAST STEEL BORING HEAD W/BOLT-ON TEETH

**STANDARD SINGLE & DOUBLE FLIGHT AUGER**

- One-piece cast steel boring head
- Hardened bolt-on gage teeth on outside positions
- Hardened bolt-on wisdom teeth on inside positions
- Hardened Fishtail Pilot
- 2" round, 2-9/16" round, 2" hex collars
- Available in 3', 4', 5' and 6' lengths

HEAVY-DUTY CAST STEEL BORING HEAD

**AGGRESSIVE DOUBLE FLIGHT AUGER**

- Heavy-duty cast steel boring head
- Hardened drive-in gage teeth on outside positions
- Hardened drive-in chisel teeth on inside positions
- Hardened Fishtail Pilot
- Heavy-duty double flighting
- 2" Round, 2-9/16" Round, 2" Hex
- Available in 3', 4', 5' and 6' lengths

ONE-PIECE CAST STEEL BORING HEAD

**TREE AUGER**

- Two-diameter design
- Fabricated boring head
- Hardened bolt-on gage teeth and wisdom teeth with hardened Pilot
- Heavy-duty double flighting
- 2" Round, 2-9/16" Round, 2" Hex



## STANDARD DUTY AUGERS

SINGLE FLIGHTING, 4FT					
MODEL #	AUGER DIAM.	TOOTH #	OUTSIDE	INSIDE	PILOT ITEM #
			TOOTH ITEM #	TOOTH ITEM #	
A04CDF4SF	4"	0	N/A	N/A	00203
A06CDF4SF	6"	2	00202	00200	
A09CDF4SF	9"	3			
A12CDF4SF	12"	4			
A15CDF4SF	15"	5			
A18CDF4SF	18"	6			
A24CDF4SF	24"	8			

DOUBLE FLIGHTING, 3FT					
MODEL #	AUGER DIAM.	TOOTH #	OUTSIDE	INSIDE	PILOT ITEM #
			TOOTH ITEM #	TOOTH ITEM #	
A04CDF3	4"	0	N/A	N/A	00203
A06CDF3	6"	2	00202	00200	
A08CDF3	8"	2			
A09CDF3	9"	3			
A10CDF3	10"	3			
A12CDF3	12"	4			
A15CDF3	15"	5			
A16CDF3	16"	5			
A18CDF3	18"	6			
A20CDF3	20"	6			
A24CDF3	24"	8			
A30CDF3	30"	9			
A36CDF3	36"	11			

DOUBLE FLIGHTING, 4FT					
MODEL #	AUGER DIAM.	TOOTH #	OUTSIDE	INSIDE	PILOT ITEM #
			TOOTH ITEM #	TOOTH ITEM #	
A04CDF4	4"	0	N/A	N/A	00203
A06CDF4	6"	2	00202	00200	
A08CDF4	8"	2			
A09CDF4	9"	3			
A10CDF4	10"	3			
A12CDF4	12"	4			
A15CDF4	15"	5			
A16CDF4	16"	5			
A18CDF4	18"	6			
A20CDF4	20"	6			
A24CDF4	24"	8			
A30CDF4	30"	9			
A36CDF4	36"	11			



## AGGRESSIVE DUTY AUGERS

DOUBLE FLIGHTING, 3FT					
MODEL #	AUGER DIAM.	TOOTH #	OUTSIDE	INSIDE	PILOT ITEM #
			TOOTH ITEM #	TOOTH ITEM #	
A06CDC3	6"	2	00202	00201	00203
A08CDC3	8"	4			
A09CDC3	9"	4			
A10CDC3	10"	4			
A12CDC3	12"	4			
A15CDC3	15"	6			
A16CDC3	16"	6			
A18CDC3	18"	6			
A20CDC3	20"	6			
A24CDC3	24"	8			
A30CDC3	30"	10			
A36CDC3	36"	12			

DOUBLE FLIGHTING, 4FT					
MODEL #	AUGER DIAM.	TOOTH #	OUTSIDE	INSIDE	PILOT ITEM #
			TOOTH ITEM #	TOOTH ITEM #	
A06CDC4	6"	2	00202	00201	00203
A08CDC4	8"	4			
A09CDC4	9"	4			
A10CDC4	10"	4			
A12CDC4	12"	4			
A15CDC4	15"	6			
A16CDC4	16"	6			
A18CDC4	18"	6			
A20CDC4	20"	6			
A24CDC4	24"	8			
A30CDC4	30"	10			
A36CDC4	36"	12			
A42CDC4	42"	16			
A48CDC4	48"	18			



## TREE AUGERS

TREE AUGER, 3FT					
MODEL #	AUGER DIAM.	TOOTH #	OUTSIDE	INSIDE	PILOT ITEM #
			TOOTH ITEM #	TOOTH ITEM #	
A18CDT3	18"	7	00202	00200	00203
A24CDT3	24"	10			
A30CDT3	30"	11			
A36CDT3	36"	13			

TREE AUGER, 4FT					
MODEL #	AUGER DIAM.	TOOTH #	OUTSIDE	INSIDE	PILOT ITEM #
			TOOTH ITEM #	TOOTH ITEM #	
A18CDT4	18"	7	00202	00200	00203
A24CDT4	24"	10			
A30CDT4	30"	11			
A36CDT4	36"	13			
A42CDT4	42"	15			
A48CDT4	48"	17			



# AUGERS



REPLACEABLE SHANK PLATES



## HIGH TORQUE AUGER

- Heavy-duty cast steel boring head w/replaceable shank plates
- Outside gage teeth, standard or carbide teeth & pilot
- 3/8" thick flighting, Extra heavy-duty center shaft
- 2-1/2" Hex, 2-5/8" Hex, 3" Hex collars available
- Available in custom lengths upon request



FABRICATED BORING HEAD



## HEAVY DUTY ROCK AUGER

- Fabricated boring head
- Bullet style teeth
- Carbide pilot
- Heavy Duty Flighting
- 3/4" Thick bottom flighting
- 2" Round, 2-9/16" Round, 2" Hex Collars Available



FABRICATED BORING HEAD W/BULLET TEETH



## HIGH TORQUE ROCK AUGER

- Fabricated boring head
- Bullet style teeth
- Heavy-duty 3/8" thick flighting
- 3/4" Thick bottom flighting, extra heavy-duty center shaft
- 2-1/2" Hex, 2-5/8" Hex, 3" Hex collars available
- Available in custom lengths upon request



STUMP PLANER HEAD



## STUMP PLANER AUGER\*

- High quality alloy dual cutting edges
- Cutting edges can be removed and sharpened
- 3/4" Thick flighting
- Center point pulls stump planer into the stump
- Replaceable center point
- 2-9/16" Round, 2" Hex, 2-1/2" Hex Collars Available

\*NOTE; TO OPERATE THE STUMP PLANER PROPERLY, THE AUGER DRIVE MUST HAVE THE FOLLOWING:  
12" STUMP PLANER 3000FTLBS OF TORQUE | 16" STUMP PLANER 5500FTLBS OF TORQUE

## HIGH TORQUE AUGERS

### HIGH TORQUE DIRT, 6FT

MODEL #	AUGER DIAM.	TOOTH #	OUTSIDE	INSIDE	PILOT ITEM #
			TOOTH ITEM #	TOOTH ITEM #	
A09HTA6	9"	2	00214	00213	00217
A12HTA6	12"	4			
A16HTA6	16"	4			
A18HTA6	18"	6			
A20HTA6	20"	6			
A24HTA6	24"	7			
A30HTA6	30"	8			
A36HTA6	36"	8			
A42HTA6	42"	12			
A48HTA6	48"	14			

### HIGH TORQUE ROCK, 6FT

MODEL #	AUGER DIAM.	TOOTH #	OUTSIDE	INSIDE	PILOT ITEM #
			TOOTH ITEM #	TOOTH ITEM #	
A09HTR6	9"	10	00221	N/A	00236
A12HTR6	12"	12			
A16HTR6	16"	16			
A18HTR6	18"	18			
A20HTR6	20"	20			
A24HTR6	24"	24			
A30HTR6	30"	30			
A36HTR6	36"	36			
A42HTR6	42"	42			
A48HTR6	48"	48			

## HEAVY DUTY ROCK AUGERS

### HEAVY DUTY ROCK AUGER, 4FT

MODEL #	AUGER DIAM.	TOOTH #	OUTSIDE	INSIDE	PILOT ITEM #
			TOOTH ITEM #	TOOTH ITEM #	
A02CDR3	2"	0	N/A		N/A
A02CDR4	2"	0			
A04CDR4	4"	0			
A06CDR4	6"	6	00221	N/A	00236
A09CDR4	9"	10			
A12CDR4	12"	12			
A16CDR4	16"	16			
A18CDR4	18"	18			
A20CDR4	20"	20			
A24CDR4	24"	24			
A30CDR4	30"	30			
A36CDR4	36"	36			

## STUMP PLANER AUGERS

### STUMP PLANER AUGER, 4FT

MODEL #	AUGER DIAM.	BLADE #	BLADE ITEM #	PILOT ITEM #
SPA12H200	12"	2	00301	00300
SPA12R256	12"		00301	
SPA16H200	16"		00303	
SPA16H250	16"		00303	





# AUGER TEETH

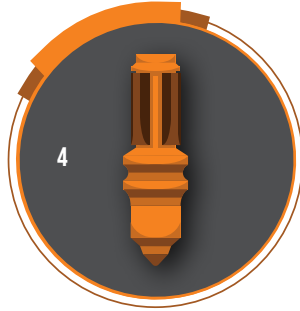

## AUGER TEETH

MODEL #	DESCRIPTION
00200	WISDOM TOOTH (1)
00201	CHISEL TOOTH (2)
00202	WISDOM GAGE TOOTH (3)
00205	HARDFACED WISDOM TOOTH
00206	HARDFACED CHISEL TOOTH
00207	HARDFACED WISDOM GAGE TOOTH
00208	CARBIDE WISDOM TOOTH
00209	CARBIDE CHISEL TOOTH
00261	CARBIDE GAGE TOOTH
00237	RB CARBIDE WISDOM TOOTH
00225	TOOTH POCKET FOR CDC AUGERS
00221	ROCK AUGER BULLET TOOTH (4)
00223	BULLET TOOTH HOLDER
40000	5/8"-11 CARRIAGE BOLT 1-1/2" LONG
40001	5/8"-11 LOCK NUT



## AUGER PILOTS

MODEL #	DESCRIPTION
00203	FISHTAIL PILOT (5)
00210	HARDFACED FISHTAIL PILOT
00211	CARBIDE FISHTAIL PILOT
00204	4-1/2" AUGER FISHTAIL PILOT
00236	CDR ROCK AUGER PILOT, 1-3/4" SQUARE SHANK (6)
00239	4" CDR ROCK AUGER BULLET TOOTH
00253	CRB ROCK AUGER FISHTAIL PILOT (7)



## HIGH TORQUE TEETH

MODEL #	DESCRIPTION
00213	UTILITY DIRT TOOTH (9)
00214	UTILITY GAGE TOOTH (8)
00215	UTILITY CARBIDE DIRT TOOTH
00216	UTILITY CARBIDE GAGE TOOTH



## HIGH TORQUE PILOTS

MODEL #	DESCRIPTION
00217	UTILITY FISHTAIL PILOT (10)
00218	UTILITY HARDFACED FISHTAIL PILOT
00219	UTILITY CARBIDE FISHTAIL PILOT
00260	CARBIDE HARDFACED FISHTAIL PILOT



**VARIABLE & FIXED LENGTH EXTENSIONS**

VARIABLE MODEL #	FIXED MODEL #	LENGTH	COLLAR
N/A	CFE12R200	12"	2" RND
N/A	CFE24R200	24"	
CVE12R256	CFE12R256	12"	2-9/16" RND
CVE24R256	CFE24R256	24"	
CVE36R256	CFE36R256	36"	
CVE48R256	CFE48R256	48"	
CVE72R256	CFE72R256	72"	
CVE12H200	CFE12H200	12"	
CVE24H200	CFE24H200	24"	
CVE36H200	CFE36H200	36"	
CVE48H200	CFE48H200	48"	
CVE72H200	CFE72H200	72"	
HVE48H250	HFE48H250	48"	2-1/2" HEX
HVE72H250	HFE72H250	72"	
HVE72H262	HFE72H262	72"	2-5/8" HEX

**VARIABLE LENGTH EXTENSION**



**FIXED LENGTH EXTENSION**



**ADAPTERS**

MODEL #	FEMALE OUTPUT	MALE OUTPUT
C200H256R	2" HEX	2-9/16" RND
C200H200R	2" HEX	2" RND
C256R200H	2-9/16" RND	2" HEX
C256R200R	2-9/16" RND	2" RND
C200R200H	2" RND	2" HEX
C200R256R	2" RND	2-9/16" RND
C200H250H	2" HEX	2-1/2" HEX
C200H262H	2" HEX	2-5/8" HEX
C250H200H	2-1/2" HEX	2" HEX
C262H200H	2-5/8" HEX	2" HEX
C250H262H	2-1/2" HEX	2-5/8" HEX
C262H250H	2-5/8" HEX	2-1/2" HEX



**HOSES & FITTINGS**

MODEL #	DESCRIPTION
61061	1/2" HYDRAULIC HOSES 68" LONG
61050	1/2" HYDRAULIC HOSES 108" LONG
61049	1/2" HYDRAULIC HOSES 120" LONG
61006	1/2" FEMALE FLAT FACED COUPLER
61007	1/2" MALE FLAT FACED COUPLER
61051	3/4" HYDRAULIC HOSE KIT 108" LONG
61043	3/4" FEMALE FLAT FACED COUPLER
61044	3/4" MALE FLAT FACED COUPLER
61008	5/8" FEMALE FLAT FACED COUPLER
61009	5/8" MALE FLAT FACED COUPLER
61022	1/2" NPT PIONEER FEMALE COUPLER
61023	1/2" NPT PIONEER MALE COUPLER
91052	SPRING 1/2" HOSE HOLDER KIT
91053	SPRING 3/4" HOSE HOLDER KIT
61070	TRACTOR REAR REMOTE HYDRAULIC HOSE KIT 240" LONG



**AUGER COLLARS**

MODEL #	DESCRIPTION
00102	2" HEX AUGER COLLAR
00101	2-9/16" ROUND AUGER COLLAR
00100	2" ROUND AUGER COLLAR
00103	2-1/2" HEX COLLAR
00104	2-5/8" HEX COLLAR



**PREMIER TORQ-HUB MONITORING SYSTEM**



MODEL #	DESCRIPTION
THMSH200	TORQ-HUB MONITORING SYSTEM (2" HEX)
THMSH250	TORQ-HUB MONITORING SYSTEM (2-1/2" HEX)
THMSH300	TORQ-HUB MONITORING SYSTEM (3" HEX)
THMSS400	TORQ-HUB MONITORING SYSTEM (4" SQUARE)



# POST DRIVERS

## MODEL 500 POST DRIVER

INCLUDES 1/2 HOSES & COUPLERS, TOOL BOX, EMPTY NITROGEN BOTTLE, RECHARGE KIT, CHAIN, 6" DOME PAD, MOIL POINT, AND POST DRIVER PASTE

MODEL #	DESCRIPTION	GPM RANGE	DOME PAD SIZE	BASE MODEL WT. W/MOUNT	AUGER DRIVE	MAX. AUGER DIAMETER
PD500MS	PD500 WITH MINI SKID STEER MOUNTING BRACKET	10-16	6"	400 LBS	N/A	24"
PD500MT	PD500 WITH BOBCAT MT MOUNTING BRACKET			410 LBS		
PD500ME	PD500 WITH MINI EXCAVATOR MOUNT BASE (*)			370 LBS		
PD500MSA	PD500 WITH MINI SKID MOUNTING BRACKET & AUGER PRE-DRILL SYSTEM (AUGER BIT NOT INCLUDED)			500 LBS	MS11	
PD500MTA	PD500 WITH BOBCAT MT MOUNTING BRACKET & AUGER PRE-DRILL SYSTEM (AUGER BIT NOT INCLUDED)			510 LBS		

## MODEL 750 POST DRIVER

INCLUDES 1/2 HOSES & COUPLERS, TOOL BOX, EMPTY NITROGEN BOTTLE, RECHARGE KIT, CHAIN, 8" DOME PAD, MOIL POINT, AND POST DRIVER PASTE

MODEL #	DESCRIPTION	GPM RANGE	DOME PAD SIZE	BASE MODEL WT. W/MOUNT	AUGER DRIVE	MAX. AUGER DIAMETER
PD750	PD750 WITH UNIVERSAL SKID STEER MOUNTING BRACKET	12-20	8"	1200 LBS	N/A	30"
PD750C	PD750 WITH COMBO POST DRIVER & CONCRETE BREAKER			1250 LBS		
PD750E	PD750 WITH EXCAVATOR MOUNT BASE (*)			1000 LBS		
PD750A	PD750 WITH AUGER PRE-DRILL SYSTEM (AUGER BIT NOT INCLUDED)			1300 LBS	MS14	

## MODEL 1000 POST DRIVER

INCLUDES 1/2 HOSES & COUPLERS, TOOL BOX, EMPTY NITROGEN BOTTLE, RECHARGE KIT, CHAIN, 9" DOME PAD, MOIL POINT, AND POST DRIVER PASTE

MODEL #	DESCRIPTION	GPM RANGE	DOME PAD SIZE	BASE MODEL WT. W/MOUNT	AUGER DRIVE	MAX. AUGER DIAMETER
PD1000	PD1000 WITH UNIVERSAL SKID STEER MOUNTING BRACKET	15-25	9"	1350 LBS	N/A	36"
PD1000C	PD1000 WITH COMBO POST DRIVER & CONCRETE BREAKER			1400 LBS		
PD1000E	PD1000 WITH EXCAVATOR MOUNT BASE (*)			1150 LBS		
PD1000A	PD1000 WITH AUGER PRE-DRILL SYSTEM (AUGER BIT NOT INCLUDED)			1450 LBS	MS18	

## MODEL 1500 POST DRIVER

INCLUDES 1/2 HOSES & COUPLERS, TOOL BOX, EMPTY NITROGEN BOTTLE, RECHARGE KIT, CHAIN, 9" DOME PAD, MOIL POINT, AND POST DRIVER PASTE

MODEL #	DESCRIPTION	GPM RANGE	DOME PAD SIZE	BASE MODEL WT. W/MOUNT	AUGER DRIVE	MAX. AUGER DIAMETER
PD1500	PD1500 WITH UNIVERSAL SKID STEER MOUNTING BRACKET	19-29	10"	1500 LBS	N/A	36"
PD1500C	PD1500 WITH COMBO POST DRIVER & CONCRETE BREAKER			1550 LBS		
PD1500E	PD1500 WITH EXCAVATOR MOUNT BASE (*)			1400 LBS		
PD1500A	PD1500 WITH AUGER PRE-DRILL SYSTEM (AUGER BIT NOT INCLUDED)			1600 LBS	MS18	

\*SPECIFIC EXCAVATOR MOUNT MAY BE ADDITIONAL COST



## POST DRIVER ACCESSORIES

### PD500 POST PADS

MODEL #	DESCRIPTION
63500	DOME POST PAD, 6" OD
63504	FLAT POST PAD, 6" OD

### PD750 POST PADS

MODEL #	DESCRIPTION
63501	DOME POST PAD, 8"OD
63505	FLAT POST PAD, 8" OD
63518	T-POST DRIVER PAD, 4"OD
63519	PIPE & T POST COMBO PAD, 5"OD
63520	DOME POST PAD, 9" OD
63521	FLAT POST PAD, 9" OD
63522	DOME POST PAD, 10" OD
63523	FLAT POST PAD, 10" OD

### PD1000 POST PADS

MODEL #	DESCRIPTION
63502	DOME POST PAD, 9" OD
63506	FLAT POST PAD, 9" OD
63527	T-POST DRIVER PAD, 4"OD
63528	PIPE & T POST COMBO PAD, 5"OD
63529	DOME POST PAD, 10" OD
63530	FLAT POST PAD, 10" OD
63531	DOME POST PAD, 11" OD
63532	FLAT POST PAD, 11" OD
63533	DOME POST PAD, 12" OD
63534	FLAT POST PAD 12" OD

### PD1500 POST PADS

MODEL #	DESCRIPTION
63503	DOME POST PAD, 10" OD
63507	FLAT POST PAD, 10" OD
63513	T-POST DRIVER PAD, 3-1/4" OD

### ROCK SPIKE TOOL

MODEL #	DESCRIPTION
63545	ROCK SPIKE, 1-3/4" OD, 48"L

### CONCRETE BREAKER TOOLS

MODEL #	DESCRIPTION
63514	CHISEL, MOIL POINT, PD500
63515	CHISEL, MOIL POINT, PD750
63516	CHISEL, MOIL POINT, PD1000
63517	CHISEL, MOIL POINT, PD1500

### POST DRIVER PASTE

MODEL #	DESCRIPTION
63201	POST DRIVER PASTE
63201	POST DRIVER PASTE CASE (10)



### POST DRIVER

We offer three configurations to choose from:

- **Basic Post Driver**  
Ideal for most jobs and conditions
- **Earth Auger Pre-Drill**  
For difficult ground conditions the pre-drill system allows operator to drill a pilot hole to assist in driving posts more efficiently.
- **Combo Driver/Breaker**  
This post driver becomes a concrete breaker as well as a post driver





# MINI SKID STEER TRENCHERS

## T100 TRENCHER

MIN/MAX HYD: 8-12		MIN/MAX PSI: 2,500-3,500			
MIN/MAX RPM: 102-154		MIN/MAX TORQUE: 597-716			
BOOM LEN.	CUT WIDTH	DOUBLE STD CHAIN	50/50 SHARK TOOTH CHAIN	50/50 BULLET TOOTH CHAIN	70/30 SCORPION CHAIN
3'	4"	T100-36DS-4W	T100-36ST55-4W	T100-36BT55-4W	T100-36ST73-4W
	6"	T100-36DS-6W	T100-36ST55-6W	T100-36BT55-6W	T100-36ST73-6W
	8"	T100-36DS-8W	T100-36ST55-8W	T100-36BT55-8W	T100-36ST73-8W
	10"	T100-36DS-10W	T100-36ST-10W	T100-36BT55-10W	T100-36ST73-10W
	12"	T100-36DS-12W	T100-36ST-12W	T100-36BT55-12W	T100-36ST73-12W

CUSTOM LENGTHS AVAILABLE UPON REQUEST

## T125 TRENCHER WITH DUO-TACH™

MIN/MAX HYD: 10-15		MIN/MAX PSI: 2,500-3,000			
MIN/MAX RPM: 101-151		MIN/MAX TORQUE: 765-918			
BOOM LEN.	CUT WIDTH	DOUBLE STD CHAIN	50/50 SHARK TOOTH CHAIN	50/50 BULLET TOOTH CHAIN	70/30 SCORPION CHAIN
3'	4"	T125-36DS-4W	T125-36ST55-4W	T125-36BT55-4W	T125-36ST73-4W
	6"	T125-36DS-6W	T125-36ST55-6W	T125-36BT55-6W	T125-36ST73-6W
	8"	T125-36DS-8W	T125-36ST55-8W	T125-36BT55-8W	T125-36ST73-8W
	10"	T125-36DS-10W	T125-36ST-10W	T125-36BT55-10W	T100-36ST73-10W
	12"	T125-36DS-12W	T125-36ST-12W	T125-36BT55-12W	T100-36ST73-12W

CUSTOM LENGTHS AVAILABLE UPON REQUEST



PATENT NO. 11,280,057

DUO-TACH™ MOUNTING SYSTEM

## T155 TRENCHER

MIN/MAX HYD: 15-19		MIN/MAX PSI: 2,500-3,500			
MIN/MAX RPM: 116-146		MIN/MAX TORQUE: 995-1393			
BOOM LEN.	CUT WIDTH	DOUBLE STD CHAIN	50/50 SHARK TOOTH CHAIN	50/50 BULLET TOOTH CHAIN	70/30 SCORPION CHAIN
3'	6"	T155-3DS-6W	T155-3ST55-6W	T155-3BT55-6W	T155-3ST73-6W
	8"	T155-3DS-8W			
	10"	T155-3DS-10W			
	12"	T155-3DS-12W			
4'	6"	T155-4DS-6W	T155-4ST55-6W	T155-4BT55-6W	T155-4ST73-6W
	8"	T155-4DS-8W	T155-4ST55-12W		

## T255 TRENCHER

MIN/MAX HYD: 19-27		MIN/MAX PSI: 2,500-3,500			
MIN/MAX RPM: 120-170		MIN/MAX TORQUE: 1,219-1,706			
BOOM LEN.	CUT WIDTH	DOUBLE STD CHAIN	50/50 SHARK TOOTH CHAIN	50/50 BULLET TOOTH CHAIN	70/30 SCORPION CHAIN
3'	6"	T255-3DS-6W	T255-3ST55-6W	T255-3BT55-6W	T255-3ST73-6W
	8"	T255-3DS-8W			
	10"	T255-3DS-10W			
	12"	T255-3DS-12W			
4'	6"	T255-4DS-6W	T255-4ST55-6W	T255-4BT55-6W	T255-4ST73-6W
	8"	T255-4DS-8W			

## T350 TRENCHER

MIN/MAX HYD: 30-39		MIN/MAX PSI: 2,500-3,500			
MIN/MAX RPM: 155-202		MIN/MAX TORQUE: 1,480-2,072			
BOOM LEN.	CUT WIDTH	DOUBLE STD CHAIN	50/50 SHARK TOOTH CHAIN	50/50 BULLET TOOTH CHAIN	70/30 SCORPION CHAIN
3'	6"	T350-3DS-6W	T350-3ST55-6W	T350-3BT55-6W	T350-3ST73-6W
	8"	T350-3DS-8W			
	10"	T350-3DS-10W			
	12"	T350-3DS-12W			
4'	6"	T350-4DS-6W	T350-4ST55-6W	T350-4BT55-6W	T350-4ST73-6W
	8"	T350-4DS-8W			
5'	6"	T350-5DS-6W	T350-5ST55-6W	T350-5BT55-6W	T350-5ST73-6W

CUSTOM LENGTHS AVAILABLE UPON REQUEST

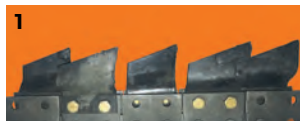

### TRENCHERS

Premier Trencher Attachments utilize the power of the host machine to deliver high performance

- Premier's newly patented **DUO-TACH™ Mounting System** allows trenchers to be used on both universal skid steer and mini skid steer mounting systems. Disconnect the mount from your full-size skid steer and re-connect it to your mini skid steer without changing anything.
- Heavy Duty Planetary Drive system eliminates chain reduction
- Heavy-Duty crumber shoe accessory for loose soil removal
- Replaceable spoil auger mounts most soil to one side of the trench
- Manual side-shift for trenching close to the structure
- Built-in skid shoe provides proper auger depth control
- Built-in mechanical depth gauge
- 2 Year Motor and Planetary/1 Year Frame Warranty

### TRENCHER CHAIN OPTIONS

- **Double Standard Chain (1)**  
Recommended for harder, drier soil conditions
- **50/50 Bullet Tooth Chain (2)**  
Recommended for hard soils, frost, and rocky conditions
- **50/50 Shark Tooth Chain (3)**  
Recommended for consistent hard soil/rock conditions
- **70/30 Scorpion Tooth Chain (4)**  
Recommended for hard soil, rock, asphalt, and frozen ground conditions

## M-SERIES - CLASSIC AMMBUSHER MOWERS

MODEL #	WIDTH	GPM	DESCRIPTION	MAX. CUT CAPACITY	# BLADES	BLADE THICKNESS	BLADE MATERIAL	BLADE TIP SPEED		APPROX. WEIGHT
								MIN FPM	MAX FPM	
AM601-8	60"	14-17	STANDARD BRUSH MOWER	3"	2	1/2"	5160 FORGED	1,225	14,881	1,115 LBS.
AM601-10		18-21						12,605	14,706	
AM601-12		22-28						12,838	16,340	
AM720-10	72"	15-18	STANDARD BRUSH MOWER	3"	2	1/2"	5160 FORGED	12,605	15,126	1,400 LBS.
AM720-12		19-23						13,305	16,107	
AM720-14		27-29						16,207	17,407	

## AG720 & AP720 SERIES - HEAVY DUTY BRUSH CUTTERS

	MODEL #	WIDTH	GPM	DESCRIPTION	MAX. CUT CAPACITY	# BLADES	BLADE THICKNESS	BLADE MATERIAL	BLADE TIP SPEED		APPROX. WEIGHT
									MIN FPM	MAX FPM	
GEAR	AG720-3-30	72"	16-26	OPEN FRONT, HEAVY DUTY BRUSH CUTTER	8"	3	1/2"	5160 FORGED	11,689	18,995	1,645 LBS.
	AG720-3-40		21-34						11,501	18,621	
	AG720-3-45		24-39						11,689	18,995	
GEAR	AG720-4-30	72"	16-26	OPEN FRONT, HEAVY DUTY BRUSH CUTTER, W/CARBIDE BLADE CARRIER	8"	4	1/2"	5160 FORGED	11,689	18,995	2,105 LBS.
	AG720-4-40		21-34						11,501	18,621	
	AG720-4-45		24-39						11,689	18,995	
PISTON	AP720-3-30	72"	16-26	OPEN FRONT, BRUSH CUTTER, STANDARD BLADE CARRIER, PISTON MOTOR	8"	3	1/2"	5160 FORGED	11,421	18,560	1,685 LBS.
	AP720-3-40		21-34						11,620	18,622	
	AP720-3-45		24-39						11,823	18,346	
	AP720-4-30	72"	16-26	OPEN FRONT, BRUSH CUTTER, W/CARBIDE BLADE CARRIER, PISTON MOTOR	8"	4	1/2"	5160 FORGED	11,421	18,560	2,005 LBS.
	AP720-4-40		21-34						11,620	18,622	
AP720-4-45	24-39		11,823						18,346		

## AG840 & AP840 SERIES - HEAVY DUTY BRUSH CUTTERS

	MODEL #	WIDTH	GPM	DESCRIPTION	MAX. CUT CAPACITY	# BLADES	BLADE THICKNESS	BLADE MATERIAL	BLADE TIP SPEED		APPROX. WEIGHT
									MIN FPM	MAX FPM	
GEAR	AG840-3-35	84"	16-26	OPEN FRONT, HEAVY DUTY BRUSH CUTTER	8"	3	1/2"	5160 FORGED	11,694	18,273	2,037 LBS.
	AG840-3-45		20-34						11,364	18,751	
	AG840-4-35	84"	16-26	OPEN FRONT, HEAVY DUTY BRUSH CUTTER, W/CARBIDE BLADE CARRIER	8"	4	1/2"	5160 FORGED	11,694	18,273	2,233 LBS.
AG840-4-45	20-34		11,364						18,751		
PISTON	AP840-3-35	84"	16-26	OPEN FRONT, BRUSH CUTTER, STANDARD BLADE CARRIER, PISTON MOTOR	8"	3	1/2"	5160 FORGED	11,421	18,560	2,077 LBS.
	AP840-3-45		21-34						11,658	18,876	
	AP840-3-55		28-45						11,659	18,737	
	AP840-4-35	84"	16-26	OPEN FRONT, BRUSH CUTTER, W/CARBIDE BLADE CARRIER, PISTON MOTOR	8"	4	1/2"	5160 FORGED	11,421	18,560	2,275 LBS.
	AP840-4-45		21-34						11,658	18,876	
AP840-4-55	28-45		11,659						18,737		

## AC-SERIES - HEAVY DUTY INDUSTRIAL GRADE BRUSH CUTTER

	MODEL #	WIDTH	GPM	DESCRIPTION	MAX. CUT CAPACITY	# BLADES	BLADE THICKNESS	BLADE MATERIAL	BLADE TIP SPEED		APPROX. WEIGHT
									MIN FPM	MAX FPM	
PISTON	AC720CE	72"	29-45	HIGH FLOW, OPEN FRONT, HEAVY DUTY BRUSH CUTTER, CARBIDE TEETH, PISTON MOTOR	10"	4	3/4"	AR400	11,823	18,346	2,380 LBS.
	AC840CE	84"	29-45	HIGH FLOW, OPEN FRONT, HEAVY DUTY BRUSH CUTTER, CARBIDE TEETH, PISTON MOTOR	10"	4	3/4"	AR400	11,659	18,737	2,505 LBS.

## CLOSED FRONT CONVERSION KIT - FOR ALL MODELS

MODEL #	WIDTH	DESCRIPTION
CFK-72	72"	72" CLOSED FRONT CONVERSION KIT
CFK-84	84"	84" CLOSED FRONT CONVERSION KIT



## M-SERIES MOWERS, AM601 & AM720

MODEL #	DESCRIPTION	APPROX. WEIGHT
84562	60" AMMBUSHER BLADE, 19-1/2" (COMES WITH BLADE NUT)	10 LBS.
84957	72" AMMBUSHER BLADE, 24-1/2" (COMES WITH BLADE NUT)	13 LBS.
84365	BLADE BOLTS	1.5 LBS.
84363	BLADE NUT	.5 LBS.
84322	E-20 SHOCK COUPLER	4 LBS.
84379	1/2" ROLL PIN	.125 LBS.

## C-SERIES BRUSH CUTTERS, AC720C

MODEL #	DESCRIPTION	APPROX. WEIGHT
87540	AC720 BLADE (COMES WITH BLADE NUT)	19 LBS.
87534	AC720 BLADE PUCK	1.5 LBS.
87542	AC720 CARBIDE TEETH	.25 LBS.
40069	CARBIDE TOOTH NUT	.8 OZ.

## D-SERIES BRUSH CUTTERS, DL66 & DL72

MODEL #	DESCRIPTION	APPROX. WEIGHT
85225	DL66 BLADE (COMES WITH NUT)	7 LBS.
85528	DL72 BLADE (COMES WITH NUT)	10 LBS.
84365	BLADE BOLTS	1.5 LBS.
84363	BLADE NUT	.5 LBS.

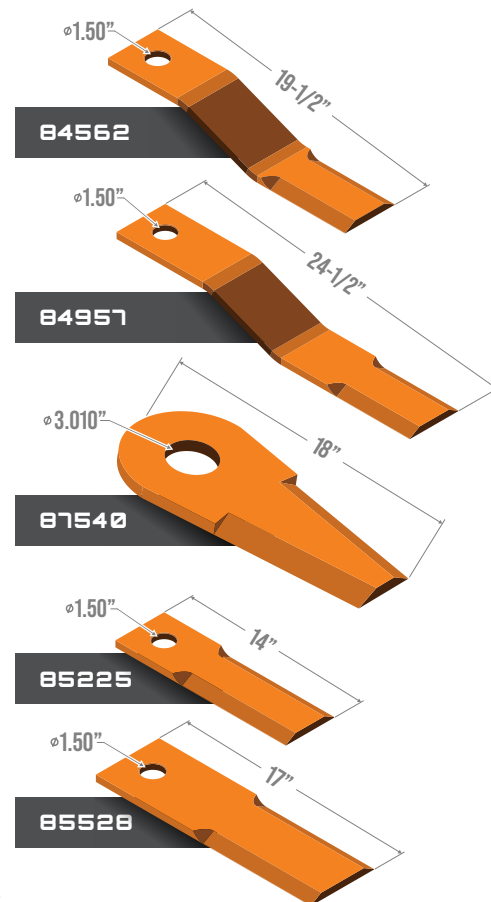

For over 25 years, Ammbusher has built safe and reliable Mowers and Brush Cutters. Designed to fit all brands of skid steer loaders and both Standard Flow and High Flow hydraulic systems.

**NEW** for this year is the addition of our new **PISTON** models. You can find them in both 72" and 84" widths. All Piston models come with 3 or 4 blade configuration and the option of a carbide blade carrier or standard blade carrier.

### BRUSH CUTTER FEATURES

- AG models designate Gear Motors
- AP models designate PISTON Motors
- Both AG & AP models have a cut capacity of 8"
- AC Models have a cut capacity of 10"
- NEW 84" cut width available
- Spindle interrupters prevent wire, twine, and vegetation from wrapping driveshaft
- Built in pressure relief valve to protect the hydraulic motor

### PISTON MOTOR FEATURES

- Piston Motor is highly efficient
- Utilizes more of the available hydraulic system than other motors
- Better system utilization equals higher torque
- Piston motor reaches higher torque faster than other motors
- Very quick recovery time from stall

### MOWER FEATURES

- Available on 60" & 72" cutting widths
- Rubberized drive coupler helps protect motor and gearbox from impact
- Heavy-duty round stump jumper with dual free swinging blades
- Built-in pressure relief valve for fast blade rotation shut down



## CLASS I MINI SKID STEER PALLET FORKS

MODEL #	TINE LENGTH	DESCRIPTION
PF32MSC1	32"	MINI PALLET FORK 2000 LBS
PF36MSC1	36"	
PF42MSC1	42"	
PF48MSC1	48"	
PF32MTC1	32"	BOBCAT MT MINI PALLET FORK 2000 LBS
PF36MTC1	36"	
PF42MTC1	42"	
PF48MTC1	48"	

## CLASS I TRACTOR LOADER MOUNT

MODEL #	TINE LENGTH	DESCRIPTION
PF32SSC1	32"	UNIVERSAL SSL FOR COMPACT TRACTORS 2000 LBS
PF36SSC1	36"	
PF42SSC1	42"	
PF48SSC1	48"	
PF32JDC1	32"	JOHN DEERE COMPACT TRACTORS, 2000 LBS
PF36JDC1	36"	
PF42JDC1	42"	
PF48JDC1	48"	

## CLASS II TRACTOR LOADER MOUNT

MODEL #	TINE LENGTH	DESCRIPTION
PF48-G	48"	EURO/GLOBAL FORKS 4000 LBS
PF48JD	48"	JOHN DEERE 400/500 4000 LBS

## CLASS II STANDARD SKID STEER MOUNT & STANDARD BRICK GUARD

MODEL #	TINE LENGTH	DESCRIPTION
PF42-4K	42"	PALLET FORK, STANDARD MOUNT, STANDARD BRICK GUARD 4,000 LBS
PF48-4K	48"	
PF42-6K	42"	PALLET FORK, STANDARD MOUNT, STANDARD BRICK GUARD 5,500 LBS
PF48-6K	48"	
PF60-6K	48"	PALLET FORK, STANDARD MOUNT, STANDARD BRICK GUARD 5,500 LBS

## CLASS II STANDARD SKID STEER MOUNT & WALK THRU BRICK GUARD

MODEL #	TINE LENGTH	DESCRIPTION
PF42W-4K	42"	PALLET FORK, STANDARD MOUNT, WALK THRU BRICK GUARD 4,000 LBS
PF48W-4K	48"	
PF42W-6K	42"	PALLET FORK, STANDARD MOUNT, WALK THRU BRICK GUARD 5,500 LBS
PF48W-6K	48"	
PF60W-6K	48"	PALLET FORK, STANDARD MOUNT, WALK THRU BRICK GUARD 5,500 LBS

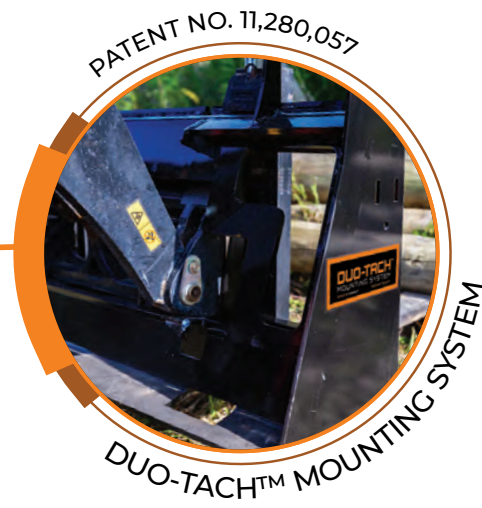

PATENT NO. 11,280,057

DUO-TACH™ MOUNTING SYSTEM



## DUO-TACH™ COMBO

CLASS II STANDARD BRICK GUARD			CLASS II WALK THROUGH BRICK GUARD		
MODEL #	TINE LENGTH	DESCRIPTION	MODEL #	TINE LENGTH	DESCRIPTION
PF42I-4K	42"	PALLET FORK, DUO-TACH MOUNT, STANDARD BRICK GUARD, 4,000 LBS TINE	PF42IW-4K	42"	PALLET FORK, DUO-TACH MOUNT, WALK THRU BRICK GUARD, 4000 LBS TINE
PF48I-4K	48"		PF48IW-4K	48"	
PF42I-6K	42"	PALLET FORK, DUO-TACH MOUNT, STANDARD BRICK GUARD, 5,500 LBS TINE	PF42IW-6K	42"	PALLET FORK, DUO-TACH MOUNT, WALK THRU BRICK GUARD, 5500 LBS TINE
PF48I-6K	48"		PF48IW-6K	48"	
PF60I-6K	60"		PF60IW-6K	60"	



## CLASS III HEAVY DUTY UNIVERSAL SKID STEER

MODEL #	TINE LENGTH	DESCRIPTION
PF48HDC3	48"	PALLET FORK 8000 LBS, CLASS III
PF48C3W	48" WIDE FRAME	
PF60HDC3	60"	
PF60C3W	60" WIDE FRAME	

## DRIVE IN FORKS

MODEL #	DESCRIPTION
DPF48	DRIVE-IN FORKS, 5000 LBS, CLASS II 39" BUCKET OPENING (INCLUDES 4 BUCKET FORK HOOKS)
52075	BUCKET FORK HOOKS



## PALLET FORKS

Premier's newly patented **DUO-TACH™ MOUNTING SYSTEM** allows pallet forks use on both universal skid steer and mini skid steer mounting systems. Disconnect the mount from your full-size skid steer and re-connect it to your mini skid steer without changing anything. With the newer generations of more powerful mini skid loaders, you have one mounting system to work on multiple platforms saving time and money

- A unique center of frame chain-drop connection point to handle the tough jobs. Allows up to a 3/8" thick chain to be utilized
- Extra room between the brick guard and the skid steer, making entry and exit easier on the skid steer
- Forks available in 42", 48", 60" lengths
- Fork capacity rating of 4000, 6000, and 8000 lbs
- Removable center section of the brick guard for easier entry and exit into the skid steer

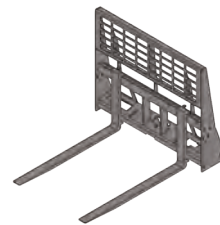

Standard Skid Steer with Standard Brick Guard

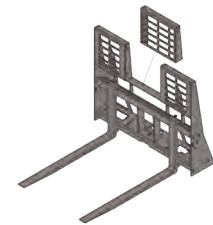

Standard Skid Steer with Walk Thru Brick Guard



**DUO-TACH** Combo Skid Steer and Mini Skid Steer with Standard Brick Guard



**DUO-TACH** Combo Skid Steer and Mini Skid Steer with Walk Thru Brick Guard





## BALE SPEAR FEATURES

- High-Quality German-made tines - 2800 Lb. capacity
- Standard and Double bale spear designs
- High back option
- Fits Universal Skid Steer mounts



PREMIUM, HAND-WELDED



## BALE SPEARS

MODEL #	WEIGHT	TINE LENGTH	DESCRIPTION
BS001	235 LBS	48"	BALE SPEAR,
BS002	265 LBS	48"	DOUBLE BALE SPEAR,
NOTE	20 LBS	HIGH BACK OPTION FOR BALE SPEAR FRAME	



## CEMENT MIXER

MODEL #	DESCRIPTION
CMH200	CEMENT MIXER KIT 2" HEX, BOWL & CRADLE
CMR256	CEMENT MIXER KIT 2-9/16" RND, BOWL & CRADLE
CMMSH200	MINI SKID STEER CEMENT MIXER KIT 2" HEX, BOWL
CMMSR256	MINI SKID STEER CEMENT MIXER KIT 2-9/16" RND, BOWL



# PREMIER ATTACHMENTS

BUILDING A LEGACY FROM THE GROUND UP

Premier Attachments began in 2001 with a commitment to building products with the highest quality components possible, Premier has chosen to utilize components that are proven and reliable.

Beginning with Hydraulic Earth Auger Drives and Augers, Premier has continued to expand our offering into other attachments. Currently, our product line includes Trenchers, Post Drivers, Ammbusher Mowers and Brush Cutters, Pallet Forks, Hay Equipment, and all the Parts & Accessories to support them all.

Our products are designed, tested, and built for the professional who demands quality and long life from their equipment. We offer competitive prices, the best warranty, unparalleled customer service, and expert product knowledge.

**We are built in the USA with  
Pride and Commitment to  
our customers.**

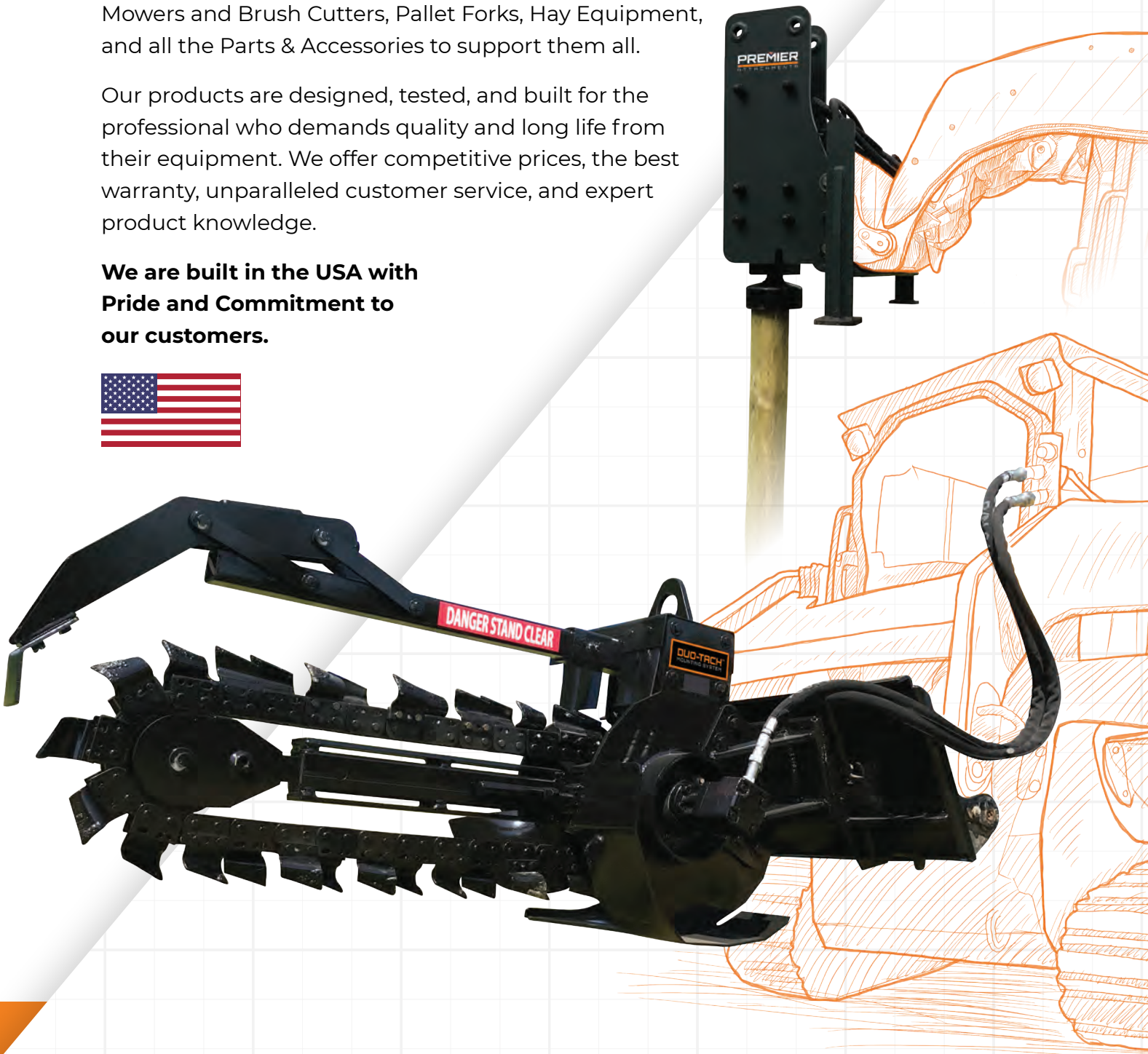





# PREMIER

---

ATTACHMENTS™

For over 20 years, Premier Attachments has designed, built and backed our lines of products with a unique brand of integrity, grit and midwest determination. We take pride in our unparalleled customer service, product knowledge, and commitment to dealers and end users alike. Unlike many of our competitors, who cheapen their products with overseas components, we are still completely **BUILT IN THE USA.**



2707 Lofty Drive  
Fort Wayne, IN 46808

Toll Free: 1.866.458.0008  
Phone: 260.456.8518  
Fax: 260.456.6868  
contact@premierattach.com

**PREMIERATTACH.COM**



**1.866.458.0008**

VERSION: **3.1**  
UPDATED: **APRIL 2022**